

MULTI-FREQUENCY MODEM IN THE INTERNET OF THINGS TECHNOLOGY

DOI: 10.36724/2072-8735-2025-19-7-51-58

Andrey V. Alyoshintsev,
Moscow State University of Civil Engineering (National research university), Moscow, Russia, alyoshintsev@mail.ru

Manuscript received 17 May 2025;
Accepted 23 June 2025

Vladimir G. Sannikov,
Moscow Technical University of Communications and Informatics, Moscow, Russia, tes_mtuci@mail.ru

Pavel D. Chelyshkov,
National Research University Higher School of Economics, Moscow, Russia, chelyshkovpd@yandex.ru

Keywords: Internet of Things, digital infrastructure, digital technologies, manufacturing project, multi-frequency modem, NB-IoT technology, intelligent building

The Internet of Things technology provides modern opportunities for the construction of facilities, is dynamic and promising, connecting devices (for example, to the monitoring system) through communication systems using a multi-frequency modem. The dispatch service, interacting with sensors, collects information about events, making adjustments to the work using actuators, while there is a need for multi-frequency data transmission. Data provide information related to the object, allowing to control it. The technology in question is recognized as one of the most important technologies of the future, applied at all stages of the life cycle of a production project, which is presented (in tabular form) in the article (reflecting the advantages). The work describes in detail the need for Internet of Things technology in the construction of Intelligent Buildings, considers the principles of implementing the Internet of Things (with recommendations for implementation at a manufacturing enterprise), gives the main types and tools (meeting the requirements of the technology). The possibility of observing certain parameters of systems to optimize construction processes is shown (in tabular form). A simplified typical model of interaction between system modules, a network organization diagram, and its characteristics are given. The structural diagram of one of the channels of the developed modem reflects its ability to process broadcast information taking into account the feasibility of using a narrowband finite signal and its two derivatives. The NB-IoT technology is described, which is part of the 5G network standards for transmitting short messages by narrowband signals. The possibility of monitoring with control functions in messengers is mentioned (with an example of possible service indication). The Interuniversity WorldSkills Championships which are regularly held emphasize the relevance of the research topic, and the predicted growth of the Internet of Things expansion up to space confirms it. The article is devoted to an overview of the Internet of Things technology applied to the construction of hybrid communications systems of a digital city whilst the development of this technology continues, and a multi-frequency modem perfectly meets the needs of this technology.

Для цитирования:

Алёшинцев А.В., Санников В.Г. Чельишков П.Д. Многочастотный модем в технологии "Интернет вещей" // Т-Комм: Телекоммуникации и транспорт. 2025. Том 19. №7. С. 51-58.

For citation:

A.V. Alyoshintsev, V.G. Sannikov, P.D. Chelyshkov, "Multi-frequency modem in the Internet of Things technology," *T-Comm*, 2025, vol. 19, no. 7, pp. 51-58.

Introduction

Digitalization of economic sectors requires the development of methods for connecting devices to the Internet of Things (IoT). At the same time, the concept of building and developing a new class of technologies in the Russian Federation up to 2030 - narrowband wireless communication networks IoT involves the transmission of small amounts of data over significant distances. This concept was developed in accordance with the Decree of the President of the Russian Federation No. 204 of May 7, 2018 and the Digital Economy of the Russian Federation program of July 2, 2017, calling for limiting the use of outdated platforms and technologies and stimulating the implementation of advanced ones. For Russia, digitalization issues are relevant due to the economic need for effective facility management [1].

One of the main industries subject to active implementation of the IoT network is Construction and Housing and Public Utilities.

IoT is the most important technology of the future in all sectors of the economy [2]. For example, when communicating with subcontractors, companies use sensors to collect data on their deliveries, in addition to this, in real time (continuously) they receive: data on location, temperature, humidity and other environmental parameters that affect the quality of the final product.

In contrast to specialized automatic control systems, IoT devices are based on open digital standards and protocols, which allows to implement an arbitrary technical solution from ready-made components [3]. The technology has high performance characteristics, the ability to scale, integrate and is designed for a long period of use.

The concept of IoT has existed for a long time, the number of IoT devices reaches 64 billion, the data received from devices is combined into "big data" [4]. Various IoT services use IoT methods, providing previously unavailable capabilities. The dispatch service, interacting with sensors, collects data about events (related to their physical properties), making adjustments to the work using actuators.

IoT technology is integrated into existing production technologies. Adding elements (to those already present on the object) provides analysis of the current state, improving functionality. At the same time: monitoring is security, access control is protection, and analysis is support for the reliability of the system.

Project life cycle

The use of IoT increases the efficiency and competitiveness of economic entities in the industry (the customer-designer-contractor chain) [5], provides the opportunity to look at how systems work in real time, evaluate all information (from machine performance to supply chains and logistics operations) [6].

The five stages of the project life cycle, with a list of work tasks to be solved, are summarized in Table 1, reflecting the benefits of implementing digitalization [1].

The life cycle of IoT solutions is implemented by the following companies:

1. A company which is an analyst in a specific IoT subject area.
2. A supplier of hardware and software solutions.
3. An integrator company.
4. A company supporting the IoT solution [7].

Table 1

Project life cycle stages

No	Stage	Solved work tasks	Benefits of digitalization
1	Pre-project	Agreeing and justifying the goal	Saving time and money
2	Design	Development of the project plan and content	Improving accuracy
3	Construction	Construction, coordination, launch	Quality control of works
4	Operation	Monitoring, management, maintenance	Prevention of emergencies
5	Closing	Efficiency analysis, dismantling of the facility	Determination of an effective and safe method of dismantling elements and the order of demolition of the building, with an assessment of possible risks and problems

IoT technologies are pushing the construction industry forward: at the same time, communication between objects is improved, safety at construction sites is increased, accidents are reduced, and work processes are optimized [8].

A fundamental aspect of IoT is the fact that it focuses on resources and requires a formal and machine-readable representation of these resources (devices, sensors, actuators, or machines) in the form of open standards [9]. Digital technologies are changing the ways of planning, building, maintaining, operating, and using social and economic infrastructure, and information modeling technologies (IMTs) are transforming the industry [10].

Internet of Things at the Enterprise

When implementing the IoT in the work process of an industrial enterprise, it is necessary to consolidate data from different sources, use integration and communication technologies, carefully plan the process and respect safety requirements. Compliance with the listed principles of implementing the IoT allows achieving the set goals [11]. The principles of implementing the IoT at a construction enterprise are summarized in Table 2, which shows how the direction and recommended solution for implementation are carried out depending on the factors.

Table 2

Principles of implementing the Internet of Things in a construction company

Principles	Factors	Direction	Solutions
Purposefulness	Clear goals and objectives	Optimizing resource usage	Select test areas. Check infrastructure.
Analysis and planning	Infrastructure	Analysis of current processes and systems	Create a plan to implement suitable devices
Data Analytics	Identifying trends	Forecasting problems and optimizing processes	Select data processing and analysis tools
Scalability	Changing infrastructure	Expanding the IoT network	Add new devices (without changing the system)

Integration	Manufacturing Management Systems	Data exchange and process automation	Integration of IoT devices with existing enterprise systems
Safety	Connections and data	Enterprise protection	Encryption, authentication, privacy
Staff training	Maximizing efficiency	System support	Working with devices and tools

Types and tools of the Internet of Things

The term IoT refers to the mechanism of communication between objects and the collection of large amounts of data. IoT is changing business models, relationships and boundaries of the modern electronics industry. IoT technology, which was considered expensive for companies at the development stage, has now become a significant source of income [12]. Since 6G provides data transfer at a speed of 1 terabyte per second. This level of communication ensures accelerated development of IoT in all areas of human activity. The level of development of data transmission technologies is one of the key conditions for the development of IoT [13].

Researchers from Lomonosov Moscow State University believe that by 2030, the development of IoT can reach a completely new level. At the same time, Russia needs to actively engage in the development of 6G standards in order to avoid the problems that have arisen with frequencies for the 5G communication generation [13]. It is also necessary to take into account that with “an increase in the number of users, an increase in the speed of data transfer by the application, as well as when using multicast transmission, difficulties occur in any network. IoT is a dynamic technology, connecting devices (for example, to an Intelligent Building monitoring system) via communication systems to collect and process data, allowing the facility to be monitored. One of the tools considered in [14] that can cope with growing demands is dynamic routing, its scheme is supported, for example, by the OSPF and BGP protocols [14], in [15] segment routing is considered – as a way to organize a virtual network based on existing nodes and connections between them.

At the same time, the use of this technology eliminates the need to receive and store information about intermediate nodes located between the sender and recipient nodes, to configure and manage them, which ensures scalability and flexibility of the network architecture [15]. The source selects a path and encodes it in the packet header as an ordered list of segments. Each segment is identified by a segment identifier consisting of a 32-bit integer. Segment routing is capable of supporting services within 5G and IoT networks, taking into account the needs of the user.

In addition, digital transformation and 5G infrastructure play an important role in industrial automation. Interaction and communication between enterprise departments is beneficial and productive in terms of security, and IoT technologies expand these capabilities, thereby increasing security and promoting effective enterprise management [16].

The researcher in the work [13] predicts that as IoT devices spread – from smartphones and home appliances to self-driving cars – they will be connected into networks, exchange data with each other, including conducting microtransactions without human intervention [13]. The main types of existing IoT devices are shown in Figure 1.

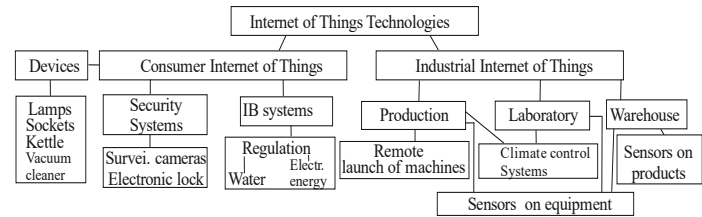

Fig. 1. Types of Internet of Things

In the study [9], the authors determined: Industrial construction uses factory production and cost-effective assembly to achieve higher production efficiency [9], and the study [17] reflects: the use of IoT technologies in various sectors of the economy makes it clear that each solution will allow companies to reduce costs and optimize labor resources, ultimately increasing production efficiency. The implementation of IoT both in large-scale production and in people's everyday life has a beneficial effect [17]. The study [18] emphasizes that the integration of classic IoT into everyday life improves comfort and safety. Smart homes equipped with IoT solutions rationalize energy consumption and serve as an additional level of protection (smart cameras and locks). IoT is transforming the world, providing new opportunities for automation and data collection [18].

Process Optimization

Researchers in [19] mention that IoT technologies incorporate multiple sensors, data processing systems, wireless networks, and system activators in a physical environment [19]. In [20], it is stated that Integration of IoT sensors into the Building Information Model (BIM) environment enables the collection, analysis, and use of large amounts of data to optimize construction processes, improve energy efficiency, ensure safety, and effectively manage facilities and systems [20]. Process optimization is summarized in Table 3.

Table 3

Process optimization

Usage	Monitoring
Construction site	Temperature, humidity (optimization of work plan, control of conditions, for example: storage of materials)
In the building	Energy consumption (identifying inefficient systems or processes)
Monitoring	System operations (optimization of energy costs, prevention of accidents and ensuring uninterrupted operation)
Security and access control	Safety of the working environment and protection of construction sites from unauthorized access
Human factor control	Monitor employee actions (for fatigue)
Analytical information	Universal access to the system from various points around the planet
Moral and ethical control over technologies	The prohibition of using against a person means and methods originally developed for his benefit and improvement of life

It should also be noted that in the study [16] the IoT architecture consists of four levels: the level of devices equipped with sensors; the level of the intermediate device; the network level; the interface level [16]. In this regard, this paper proposes a typical model shown in Figure 2.

Typical model of interaction between system blocks

The method of monitoring and transmitting data, allowing continuous diagnostics of communication channels between the control service and sensors, is described in the article [21], and in GOST R 70924-2023 Information technology. Internet of things. Typical architecture, possible examples of models are given, a simplified typical model with interactions between blocks (modules), the system is presented in Figure 2.

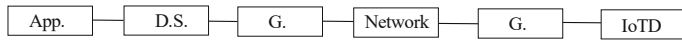

Fig. 2. Simplified standard model

Here the following notations are introduced: App. – all kinds of applications with data storage; D.S. – Dispatching service – intranet (private), user (public); IoTD – Internet of Things devices (sensors, actuators (AU)); Network block – represents communication systems, which include: local (for sensors and AU), access (global); G. – Gateway (one protects and is integrated with IoT devices, the second at the D.S. input – filters, compares, processes and manages data). Gateways are components of a communication network for interaction of heterogeneous networks. The gateway forms a channel between the local and global network, contains data storage from IoT devices, supports analytics from the D.S., contains applications (drive control based on sensor data (for local processing)). The role of the gateway is performed by a multi-frequency modem. A simplified diagram of the network organization is shown in Figure 3.

The IoT system is characterized by: 1. Performance; 2. Architecture; 3. Functionality (with self-description). Since self-description is a process when the IoT system modules provide their capabilities to inform other IoT modules or systems. The IoT module receives such broadcast information from multiple networks and systems and decides which network will best meet the module's service requirement.

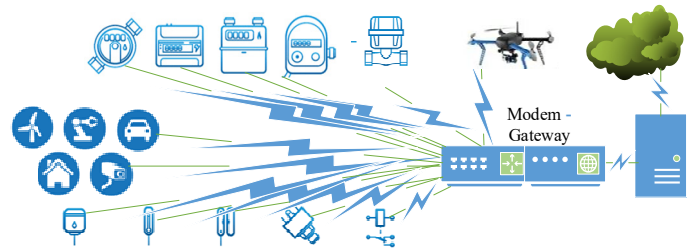

Fig. 3. Simplified network organization diagram

The interconnection of multiple broadcast networks that unite the hybrid communications systems of a digital city, including various systems used in an Intelligent Building, is a pressing issue. Multi-frequency data transmission is required.

One of the solutions for this purpose is a modem. Such a device is presented in [22], where Figure 4 shows the developed optimal multi-frequency modem that facilitates the reception/transmission of this broadcast information.

Where: $\Phi C i$, $i=1,2,3$ – finite signal generators, ΓHK – sub-carrier generator, ΦB – phase shifter on, j – block for generating complex symbols of quadrature amplitude modulation, CBH – carrier recovery circuit, Π/Π – parallel-to-serial converter on transmission and inverse on reception, $CBT\check{C}$ – clock frequency recovery circuit, $C\Phi i$, $i=1,2,3$ – matched filters for finite signals i , $i=1,2,3$, Re and Im – estimators of real and imaginary parts of complex QAM signals, $MIPY$ – multithreshold decision device. In the CBH and $CBT\check{C}$ blocks, optimal synchronization is implemented based on the assessment of the communication channel parameters [22]. The modem uses a signal and two derivatives (Fig. 5), and the level of interchannel distortion of adjacent channels with finite signals is -50 dB, as can be seen from Figure 6, which is an acceptable value when using finite signals in 5G technologies and is necessary given the high network capacity.

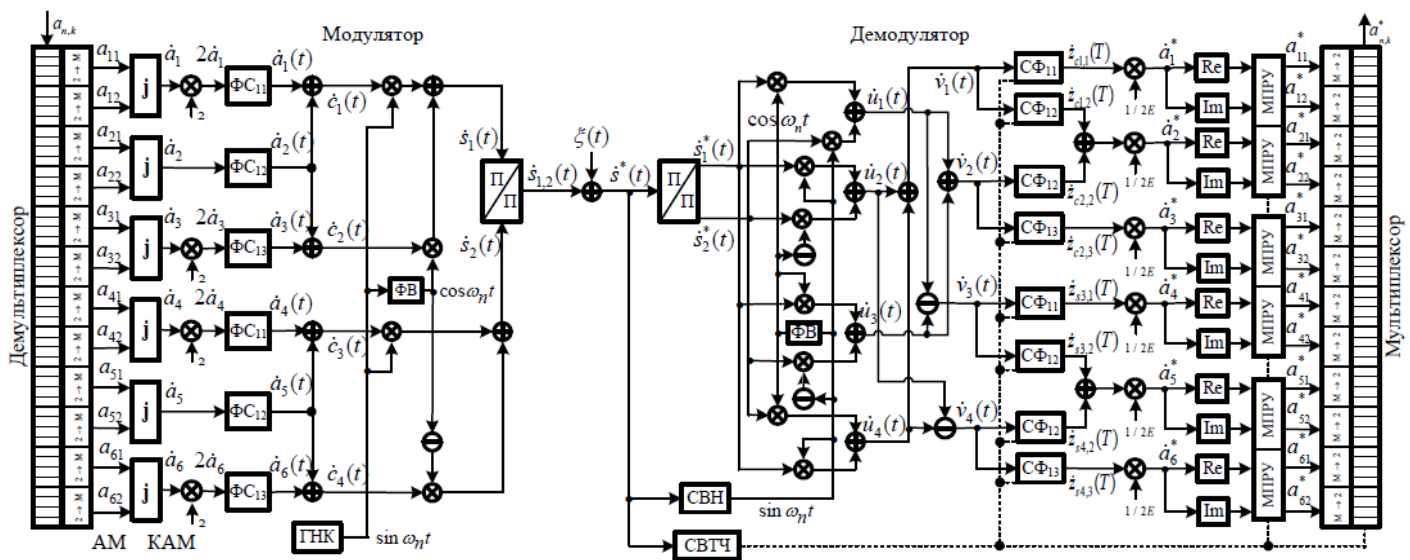

Fig. 4. Structural diagram of one modem channel

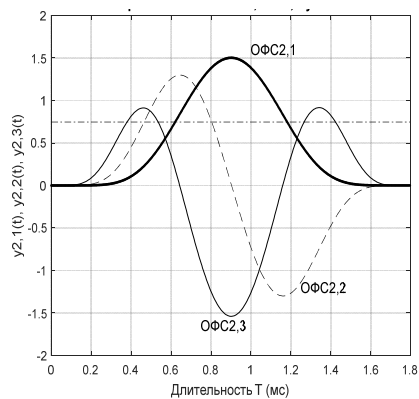

Fig. 5. Signal shape

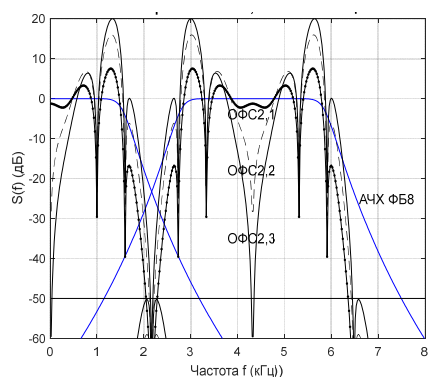

Fig. 6. Signal spectrum in the system

NB-IoT

Narrow band – Internet of things (NB-IoT). The use of radio frequencies for NB-IoT technology is regulated by GOST R 59026-2024 – Information technology. Internet of things. NB-IoT wireless data transmission protocol. The technology parameters have been recorded and have already been implemented in more than 80 regions of Russia using more than 57 thousand base stations. The requirements are: for equipment, devices, protocol stack parameters, power saving mode and network architecture, servicing a large number of devices, energy efficiency and safety. The GOST provides detailed recommendations for device developers and telecom operators for integrating solutions into the existing NB-IoT infrastructure. The use of frequencies in NB-IoT together with LTE is shown in Figure 7 and is carried out in the guard band, on subcarriers, outside the LTE channel.

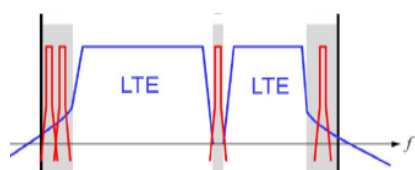

Fig. 7. Using frequencies in NB-IoT

NB-IoT technology is part of the 5G network standards, while the channel placement is similar to LTE (in the frequency band) is achieved by compatibility of modulation and frame structure, duplex configuration of the 5G frequency (aligning the subcarrier grids), and support for the "forward compatibility"

configuration. Integration with satellite communications provides greater coverage and the implementation of a "seamless transition" between networks.

The main properties of NB-IoT technology are the operation of devices in conditions of low signal levels and high noise levels, with battery savings (up to 10 years). The network is designed to occasionally transmit short messages with narrowband signals, the built-in mechanism is capable of repeating data (allowing low speed and transmission delays).

The maximum data transfer rate in the direction of the subscriber is 126 kbit/s (from the subscriber – 160 kbit/s), each base station serves up to 50 thousand devices, coverage up to 1 kilometer in the city (up to 15 kilometers in rural areas). The frequency ranges are licensed.

Monitoring with control functions in messengers

The use of Smart Home and IoT technologies maximizes the energy efficiency of residential premises, as shown in a study for private properties [23].

The study [24] uses the example of a water supply system to describe in detail how a combination of a Node-red server and a Telegram cloud messenger implements the transfer of information about the station's operation within the framework of digital IoT technologies. This approach provides access to a remote control system. The solution allows monitoring and provision of control functions. The bot provides operational control of the target installation [24]. Using the example of indication of the main categories of accidents at a water supply pumping station (Figure 8), a version of the "Dispatch Service" interface is proposed for possible deviations in its operation.

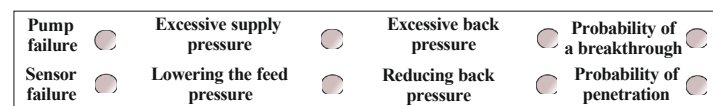

Fig. 8. Example of indication of the main categories of failures of a water supply pumping station

In [25] it is noted: The modern production process is complex, traditional control systems are no longer able to cope with this task. This is where the IoT-based control system comes into play [25]. Various data exchange platforms are being created, for example, DEP IoT is described in detail in [26] for IoT services.

Methodological development of IoT

Interuniversity WorldSkills championships in the IoT competency are held annually. Competition tasks are becoming more complex, the modern focus on industrial technology is being updated. Since a modern IoT specialist must be able to develop technical documentation, create control algorithms for complex production systems, understand the management and programming of "smart smart devices", automate production technological processes, develop intuitive interfaces for all participants in the technological process (process operator, software engineer, manager (algorithmist), technical controller) [27].

In turn, Chinese manufacturers create and use their own IoT solutions to increase productivity and reduce costs. For example, Huawei and Alibaba are developing unique platforms for manag-

ing logistics operations and monitoring the condition of equipment in real time [28].

Results and forecasts

The IOT field is not standing still. At the same time, the China Center for Industrial Information Development reports that 10 trillion yuan (1.4 trillion dollars) will be spent on artificial intelligence and the IoT [29]. The IOT fields are the following models: "Smart home, office, hotel, city". The plans include creation of a space IOT constellation consisting of 80 low-orbit communication satellites. Connecting to space capabilities is associated with a stable trend of expanding the coverage of the IOT, the number of connections to the IOT [29].

Conclusion

The multi-frequency modem is applicable in the IoT technology. The IoT technology itself is recognized as one of the most important technologies of the future, used at all stages of the life cycle of a production project. The paper describes in detail the need for IoT technology in the construction of Intelligent Buildings, and an overview of the principles of implementing IoT at a manufacturing enterprise and the main types of IoT provide a complete picture of the technology.

The article shows the possibility of optimizing construction processes, provides a simplified typical model of interaction between the system modules, a simplified network organization diagram and a structural diagram of one of the modem channels, which reflects its ability to process broadcast information, taking into account the feasibility of using a narrowband finite signal and its two derivatives. The NB-IoT technology is described, which is part of the 5G network standards for transmitting short messages using narrowband signals. The possibility of monitoring with control functions in messengers is mentioned and an example of possible indication is given. The Interuniversity Championships held underscore the relevance of the research topic, and the predicted growth of the spread of IoT up to space confirms it.

IoT is used in the construction of hybrid communications systems of the digital city, the development of this technology will continue, and the multi-frequency modem, in turn, contributes to the improvement of the spectral energy characteristics of this technology.

References

- [1] I. A. Chernyavsky, N. S. Larin, "Digitalization of processes at all stages of the life cycle of a capital construction project", *Engineering Bulletin of the Don*. 2023. No. 4 (100), pp. 773-785. (in Russian)
- [2] I. S. Lafutkina, N. N., "Grinchar Analysis of modern options for using the Internet of Things (IoT) in business", *Issues of sustainable development of society*. 2021. No. 9, pp. 200-205. (in Russian)
- [3] N. V. Papulovskaya, "Architecture of scalable Internet of Things systems", *28th Int. Crimean Conf. "Microwave Engineering and Telecom. Technologies" (KryMiKo'2018)*: Proc. Conf., Vol. 2. Moscow; Minsk; Sevastopol: FGAOU VO "Sevastopol. State University", 2018, pp. 505-511. (in Russian)
- [4] A. A. Paskova, "Integration of artificial intelligence technologies and the industrial Internet of Things", *Issues of sustainable development of society*. 2020. No. 4-2, pp. 607-612. DOI 10.34755/IROK.2020.50.70.252. (in Russian)
- [5] I. V. Bocharov, N. I. Lomakin, "Study of digital transformation in construction in the context of digitalization of the economy", *Interaction of enterprises and universities - science, personnel, new technologies: Collection of reports. XVII interregional. N. P. K., Volzhsky*: Volgograd State Technical University, 2022, pp. 84-87. (in Russian)
- [6] I. E. Fadeeva, O. M. Chernousova, "The impact of the Internet of Things (IOT) on the economy as a whole and building a business model of individual organizations," *Prospects for the development of the construction complex: Proceedings of the XV Intern. N. P. K.* 2021. Vol. 15. Astrakhan: AGASU, pp. 573-576. (in Russian)
- [7] E. G. Andrianova, O. L. Golovin, G. B. Konyaev, D. A. Polikashchkin, A. V. Poltorak, "On the development and standardization of Internet of Things and Objects technologies (IOT/IOT/M2M) in Russia with the participation of Russian companies", *IT-Standard*. 2016. No. 4(9), pp. 45-49. (in Russian)
- [8] E. A. Serdyukova, "IoT Technology in Construction, Industry and Implementation of Smart City and Smart Home Ideas", *Student year 2022: collection of articles of the XXII MNIK*, Penza: Science and Education, 2022, pp. 50-54. (in Russian)
- [9] V. P. Kupriyanovsky, O. N. Pokusaev, D. E. Namiot, A. A. Klimov, M. G. Zhabitsky, "Digital Concrete: Open BIM, Machine-Readable Standards, IoT, Digital Twins, Logistics 4.0, Lean Construction, and Other Industrial Approaches Using Transport Infrastructure Examples", *International Journal of Open Information Technologies*. 2021. Vol. 9, No. 9, pp. 133-173. (in Russian)
- [10] V. I. Bazhenov, "Information modeling technologies for water supply and sanitation infrastructure facilities", *Best available technologies for water supply and sanitation*. 2023. No. 2, pp. 11-24. (in Russian)
- [11] N. V. Gerova, O. E. Gudkova, "Implementation of Industry 4.0 elements in the management of modern Russian enterprises using the example of the "Internet of Things (IoT)" and "cloud technologies", *The Age of Science*. 2023. No. 36, pp. 154-160. (in Russian)
- [12] I. V. Ananchenko, M. D. Al-Husseini, "Current state and development prospects of the Internet of Things (IOT) in various industries", *World science: problems and innovations: Coll. Art. Int. N.P.K.* Penza: Science and Education, 2022, pp. 33-36. (in Russian)
- [13] A. A. Gorokhov, I. M. Shcherbakov, E. A. Dibrov, "Internet of Things Technologies for Achieving Sustainable Development Goals", *Russian-Asian Legal Journal*. 2022. No. 1, pp. 10-24. DOI 10.14258/ralj(2022)1.2. (in Russian)
- [14] A. V. Alyoshintsev, "Modeling Modems in a Meshed Network Topology with Dynamic Routing", *Methodological Issues of Teaching Infocommunications in Higher Education*. 2-17. Vol. 6. No. 3, pp. 4-6. (in Russian)
- [15] A. V. Shvedov, D. V. Gadasin, A. V. Alyoshintsev, "Segment routing in data transmission networks," *T-Comm*. 2022. Vol. 16, No. 5, pp. 56-62. DOI 10.36724 / 2072-8735-2022-16-5-56-62. (in Russian)
- [16] A. V. Iordanova, D. E. Gladilin, Yu. Yu. Kurasova, K. A. Persidskaya, "Analysis of the features of using the Industrial Internet of Things to ensure industrial and environmental safety", *Waste and Resources*. 2023. Vol. 10, No. 3. DOI 10.15862 / 06INOR323. (in Russian)
- [17] O. A. Evstafiadi, I. A. Bogomolov, A. V. Klimov, V. V. Lapin, "Analysis of the effectiveness of integrating innovative IOT technologies into production processes", *Auditorium*. 2023. No. 1 (37), pp. 53-57. (in Russian)
- [18] A. V. Isaev, A. V. Svishchev, "Internet of Things technologies", *My professional career*. 2023. Vol. 2, No. 54, pp. 150-157. (in Russian)
- [19] Z. M. Ibragimova, M. A. Dzhambaldinova, "Analysis of big data on supply chain management based on IoT with the participation of industrial sectors", *Colloquium-Journal*. 2022. No. 31-1 (154), pp. 39-42. DOI 10.24412/2520-6990-2022-31154-39-42. (in Russian)
- [20] E. Yu. Nikitin, "Optimization of construction processes of linear objects using BIM technologies: experience and prospects", *Development of science and practice in a globally changing world under risk conditions: Collection. mater. XX Int. N.P.K.*, Moscow: OOO "Izd-vo

ALEF", 2023, pp. 138-146. DOI 10.34755/IROK.2023.37.78.047. (in Russian)

[21] A. V. Alyoshintsev, "Automation of life support processes of the "Intelligent Building" system", *Engineering Bulletin of the Don*. 2023. No. 2 (98), pp. 440-457. (in Russian)

[22] A. V. Alyoshintsev, V.G. Sannikov, "Optimal multi-frequency modem for intermodule interaction of hybrid communications systems of a digital city", *Engineering Bulletin of the Don*. 2024. No. 11(119), pp. 193-201. (in Russian)

[23] A. N. Lepinskikh, I. V. Poddubny, M. E. Ruzin, D. S. Kravtsov, D. A. Fedorov, "Applicability of energy-efficient, energy-saving technologies and Smart home, IOT technologies in the construction of private residential buildings in the southern part of Primorsky Krai", *Universum: technical sciences*. 2021. No. 11-1 (92), pp. 53-59. (in Russian)

[24] A. R. Belokopytov, A. V. Gulyaev, A. M. Bereznev, E. E. Ten, D. S. Fokin, "Automation and dispatching of a booster pumping station using digital technologies of the industrial IOT ecosystem", *Proceedings of the Komsomolsk-on-Amur State Technical University*. 2021. No. 7 (55), pp. 58-67. (in Russian)

[25] I. V. Kholmogorov, O. V. Borisova, "Production management system within the framework of the product life cycle based on IOT technologies", *Modern digital technologies: Proceedings of the II All-Russian Scientific and Practical Conference*, Barnaul: Altai State Tech-

nical University named after I. I. Polzunov, 2023, pp. 458-460. (in Russian)

[26] L. P. Andrianova, Z. Kh. Pavlova, M. I. Khakimyanov, "Review and analysis of regulatory requirements for a data exchange platform for Internet of Things services", *Digitalization as a driver of growth in science and education: monograph. Petrozavodsk: International Scientific Partnership Center "New Science"*, 2021, pp. 135-163. DOI 10.46916/28122021-2-978-5-00174-432-0. (in Russian)

[27] A. G. Korystikina, D. O. Nikulin, A. V. Pokidov, A. Yu. Mitchenkova, "Algorithms of technical vision applied to the Internet of Things (IoT) technology", *Modern information technology in education, science and industry: XXIII Int. conf.*, M.: OOO "Izd-vo "Ekon-Inform", 2022, pp. 54-61. (in Russian)

[28] L. O. Ostapenko, L. A. Seppen, "Industrial IOT technologies in Russia and abroad", *Molod. tretnego millennium.: collect. scientific. art. XLVII reg. stud. N.P.K.*: Part 2. Omsk: Omsk State University named after Dostoevsky, 2023, pp. 343-348. (in Russian)

[29] A. V. Pikover, "Internet of things and industrial Internet of things in the PRC", *Socio-economic results of the 13th five-year plan of the PRC and tasks 14 (2021-2025): Art. scientific. conf. Center for Economic and Social Research of China Inst. Far Eastern Branch of the Russian Academy of Sciences*. M.: Federal State Budgetary Institution of Science Institute of Far Eastern Studies of the Russian Academy of Sciences, 2021, pp. 195-209. (in Russian)

МНОГОЧАСТОТНЫЙ МОДЕМ В ТЕХНОЛОГИИ "ИНТЕРНЕТ ВЕЩЕЙ"

Алёшинцев Андрей Владимирович, Московский государственный строительный университет, Москва, Россия, alyoshintsev@mail.ru

Санников Владимир Григорьевич, Московский технический университет связи и информатики, Москва, Россия, tes_mtuci@mail.ru

Чельшков Павел Дмитриевич, НИУ Высшая Школа Экономики, Москва, Россия, chelyshkovpd@yandex.ru

Аннотация

Технология "Интернет вещей" обеспечивает современными возможностями строительство объектов, является динамичной и перспективной, подключая устройства (например, к системе мониторинга) через системы связи с использованием многочастотного модема. Диспетчерская служба, взаимодействуя с датчиками, собирает информацию о событиях, внося коррективы в работу при помощи исполнительных устройств, при этом возникает необходимость в многочастотной передаче данных. Данные предоставляют информацию, влияющую на объект, позволяя контролировать его. Рассматриваемая технология признаётся одной из важнейших технологий будущего, применяется на всех этапах жизненного цикла производственного проекта, что (таблично) в статье представлено (отражая преимущества). В работе подробно изложена потребность в технологии Интернет вещей при строительстве Интеллектуальных Зданий, рассмотрены принципы внедрения Интернет вещей (с рекомендациями реализации на производственном предприятии), даны основные виды и инструменты (реализующие требования технологии). Показана (таблично) возможность, наблюдая те или иные параметры систем оптимизировать строительные процессы. Приведена упрощённая типовая модель взаимодействия между модулями системы, схема организации сети, её характеристики. Структурная схема одного из каналов разработанного модема отражает его способность перерабатывать широкополосную информацию с учётом целесообразности использования узкополосного финитного сигнала и двух его производных. Описана технология NB-IoT являющаяся частью стандартов сетей 5G для передачи коротких сообщений узкополосными сигналами. Упомянуто о возможности мониторинга с функциями управления в мессенджерах (с приведением примера возможной индикации службы). Проводимые Межвузовские чемпионаты WorldSkills подчёркивают актуальность темы исследования, а прогнозируемый рост распространения Интернет вещей вплоть до космоса подтверждает её. Статья посвящена обзору технологии Интернет вещей применимой в строительстве систем гибридных коммуникаций цифрового города и развитие данной технологии продолжится, а многочастотный модем, для нужд данной технологии вполне подходит к применению.

Ключевые слова: Интернет вещей, цифровая инфраструктура, цифровые технологии, производственный проект, многочастотный модем, технология NB-IoT, интеллектуальное здание

Литература

1. Чернявский И.А., Ларин Н.С. Цифровизация процессов на всех этапах жизненного цикла объекта капитального строительства // Инженерный вестник Дона. 2023. № 4(100). С. 773-785.
2. Лафуткина И.С., Гринчар Н.Н. Анализ современных вариантов применения интернета вещей (IoT) в бизнесе // Вопросы устойчивого развития общества. 2021. № 9. С. 200-205.
3. Папуловская Н.В. Архитектура масштабируемых систем интернета вещей // 28-я Междунар. Крымская конф. "СВЧ-техника и телеком. технологии" (КрыМиКо'2018): Матер. конф., Том 2. Москва; Минск; Севастополь: ФГАОУ ВО "Севастополь. гос. универ.", 2018. С. 505-511.
4. Паскова А.А. Интеграция технологий искусственного интеллекта и промышленного Интернета вещей // Вопросы устойчивого развития общества. 2020. № 4-2. С. 607-612. DOI 10.34755/IROK.2020.50.70.252.
5. Бочаров И.В., Ломакин Н.И. Исследование цифровой трансформации в строительстве в условиях цифровизации экономики // Взаимодействие предприятий и вузов – наука, кадры, новые технологии : Сборник докл. XVII межрегион. Н.П.К., Волжский: Волгоградский гос. технич. университет, 2022. С. 84-87.
6. Фадеева И.Е., Черноусова О.М. Влияние Интернета вещей (IoT) на экономику в целом и выстраивание бизнес-модели отдельных организаций // Перспективы развития строительного комплекса: Материалы XV Междунар. Н.П.К. Том 15. Астрахань: АГАСУ, 2021. С. 573-576.
7. Андрианова Е.Г., Головин О.Л., Коняев Г.Б., Поликашечкин Д.А., Полторац А.В. К вопросу о развитии и стандартизации технологий Интернета вещей и объектов (IoT/IIOT/M2M) в России с участием российских компаний // ИТ-Стандарт. 2016. № 4(9). С. 45-49.
8. Сердюкова Е.А. Технология IoT в Строительстве, Промышленности и Реализации Идей Smart City и Smart Home // Студ. года 2022 : сборник статей XXII МНИК, Пенза: Наука и Просвещение, 2022. С. 50-54.
9. Куприяновский В. П., Покусаев О. Н., Намиот Д. Е., Климов А.А., Жабицкий М.Г. Цифровой бетон: открытый BIM, машиночитаемые стандарты, IoT, цифровые двойники, логистика 4.0, бережливое строительство и другие промышленные подходы на примерах транспортных инфраструктур // International Journal of Open Information Technologies. 2021. Т. 9, № 9. С. 133-173.
10. Баженов В.И. Технологии информационного моделирования для инфраструктурных объектов ВКХ // Наилучшие доступные технологии водоснабжения и водоотведения. 2023. № 2. С. 11-24.
11. Герова Н.В., Гудкова О.Е. Внедрение элементов Индустрии 4.0 в управлении современными российскими предприятиями на примере "интернет вещей (IoT)" и "облачных технологий" // Эпоха науки. 2023. № 36. С. 154-160.
12. Ананченко И.В., Ал-Хуссейни М.Д. Современное состояние и перспективы развития Интернета вещей (IoT) в разных отраслях промышленности // World science: problems and innovations: сб. ст. Междунар. Н.П.К. Пенза: Наука и Просвещение 2022. С. 33-36.
13. Горохов А.А., Щербатов И.М., Дибров Е.А. Технологии интернета вещей для достижения целей устойчивого развития // Российско-азиатский правовой журнал. 2022. № 1. С. 10-24. DOI 10.14258/raij(2022)1.2.
14. Алёшинцев А.В. Моделирование модемов в условиях многосвязной сетевой топологии с динамической маршрутизацией // Методические вопросы преподавания инфокоммуникаций в высшей школе. 2017. Т. 6. № 3. С. 4-6.
15. Shvedov A.V., Gadsin D.V., Alyoshintsev A.V. Segment routing in data transmission networks // T-Comm: Телекоммуникации и транспорт. 2022. Vol. 16, No. 5, pp. 56-62. DOI 10.36724/2072-8735-2022-16-5-56-62.
16. Иорданова А.В., Гладиллин Д.Е., Курасова Ю.Ю., Персидская К.А. Анализ особенностей использования промышленного Интернета вещей для обеспечения производственной и экологической безопасности // Отходы и ресурсы. 2023. Т. 10, № 3. DOI 10.15862/06INOR323.
17. Евстафиади О.А., Богомолов И.А., Климов А.В., Лапин В.В. Анализ результативности интеграции инновационных технологий IOT в производственные процессы // Auditorium. 2023. № 1(37). С. 53-57.
18. Исаев А.В., Свищев А.В. Технологии Интернета вещей // Моя профессиональная карьера. 2023. Т. 2, № 54. С. 150-157.
19. Ибрагимова З.М., Джамалдинова М.А. Анализ больших данных управления цепочками поставок на основе IoT при участии промышленных отраслей // Colloquium-Journal. 2022. № 31-1(154). С. 39-42. DOI 10.24412/2520-6990-2022-31154-39-42.
20. Никитин Е.Ю. Оптимизация процессов строительства линейных объектов с использованием BIM-технологий: опыт и перспективы // Развитие науки и практики в глобально меняющемся мире в условиях рисков: Сбор. матер. XX Междунар. Н.П.К., Москва: Изд-во АЛЕФ, 2023. С. 138-146. DOI 10.34755/IROK.2023.37.78.047.
21. Алёшинцев А.В. Автоматизация процессов жизнеобеспечения системы "Интеллектуальное здание" // Инженерный вестник Дона. 2023. № 2(98). С. 440-457.
22. Алёшинцев А.В., Санников В.Г. Оптимальный многочастотный модем для междоульного взаимодействия систем гибридных коммуникаций цифрового города // Инженерный вестник Дона. 2024. № 11(119). С. 193-201.
23. Лепинских А.Н., Поддубный И.В., Рузин М.Е., Кравцов Д.С., Федоров Д.А. Применимость энергоэффективных, энергосберегающих технологий и технологий Smart home, IOT при строительстве частных жилых объектов в южной части Приморского Края // Universum: технические науки. 2021. № 11-1(92). С. 53-59.
24. Белокопытов А.Р., Гуляев А.В., Березнев А.М., Тен Е.Е., Фокин Д.С. Автоматизация и диспетчеризация повышающей насосной станции с применением цифровых технологий экосистемы industrial IOT // Уч. записки Комс.-на-Амуре гос. технич. универ. 2021. № 7(55). С. 58-67.
25. Холмогоров И.В., Борисова О.В. Система управления производством в рамках жизненного цикла продукции на основе IOT технологий // Современные цифровые технологии: Материалы II Всерос. Н.П.К., Барнаул: Алтайский ГТУ им. И.И. Ползунова, 2023. С. 458-460.
26. Андрианова Л.П., Павлова З.Х., Хакимьянов М.И. Обзор и анализ нормативных требований к платформе обмена данными для служб Интернета вещей // Цифровизация как драйвер роста науки и образования: монография. Петрозаводск: Междунар. центр науч. партнерства "Новая Наука", 2021. С. 135-163. DOI 10.46916/28122021-2-978-5-00174-432-0.
27. Корыстклина А.Г., Никулин Д.О., Покидов А.В., Митченкова А.Ю. Алгоритмы технического зрения применительно к технологии Интернета вещей (IoT) // Современ. информац. технол. в образов., науке и промышл.: XXIII Междунар. конф., М.: ООО "Изд-во "Экон-Информ", 2022. С. 54-61.
28. Остапенко Л.О., Сеппенен Л.А. Промышленные IOT-технологии в России и за рубежом // Молод. третьего тысячел.: сборн. науч. ст. XLVII рег. студ. Н.П.К.: Ч 2. Омск: ОГУ им. Достоевского, 2023. С. 343-348.
29. Пиковер А.В. Интернет вещей и промышленный Интернет вещей в КНР // Соц.-экон. итоги 13-й пятилетки КНР и задачи 14 (2021-2025 гг.): Ст. науч. конф. Центра экономич. и соц. исслед. Китая Инст. Д. В. РАН, М.: ФГБУ науки Институт Дальнего Востока РАН, 2021. С. 195-209.

Информация об авторах:

Алёшинцев Андрей Владимирович, Московский государственный строительный университет, Москва, Россия

Санников Владимир Григорьевич, к.т.н., доцент, Московский технический университет связи и информатики, Москва, Россия, Москва, Россия

Чельшков Павел Дмитриевич, д.т.н., доцент, НИУ Высшая Школа Экономики, Москва, Россия